

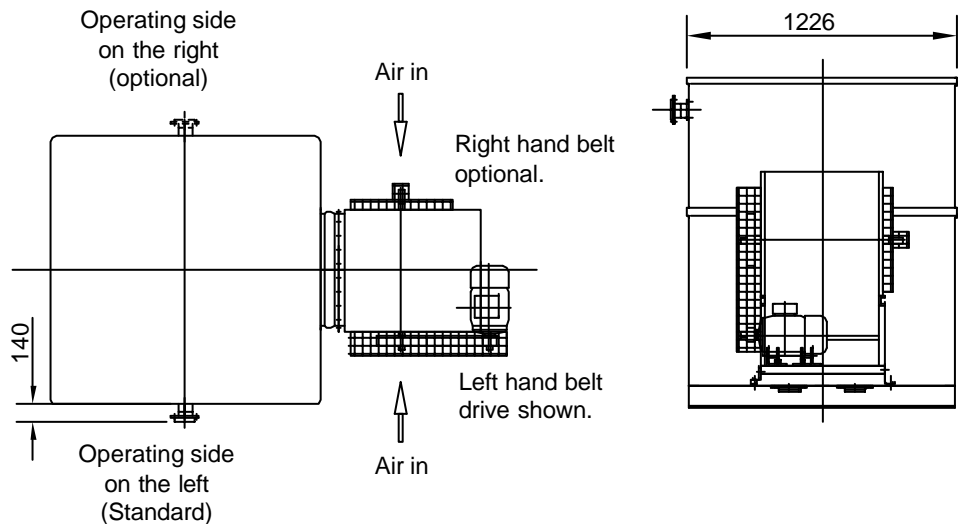

SUPERCHILL Cooling Tower EWK-D 144

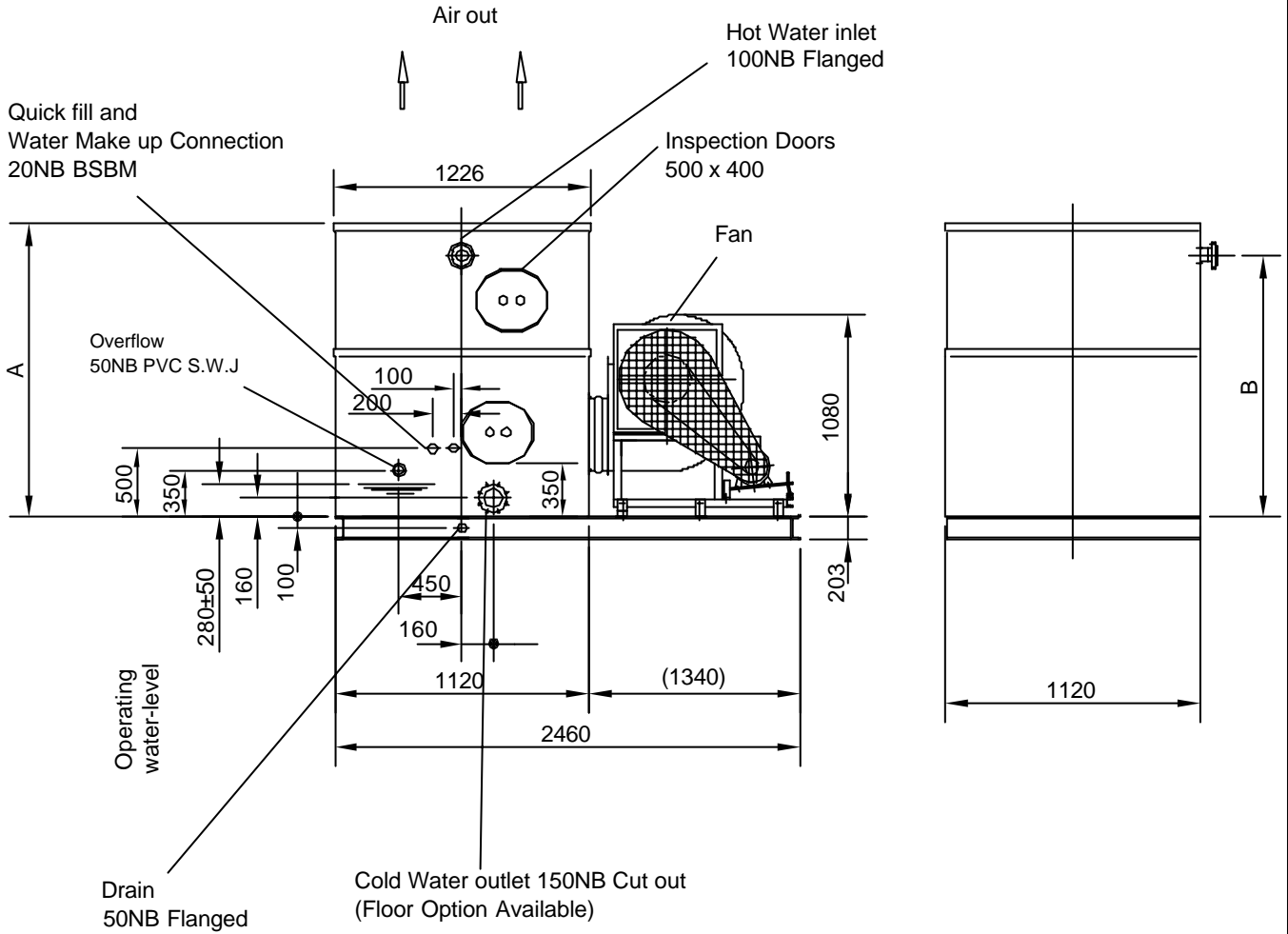

rev. date 27-03-03 / EWKD144 DIMENSION SHEET



	Weight in kg			Height	Fill Height	
	Empty	Operating	Max		600	900
Cooling tower total	600	1200	1800	A	1975	2275
				B	1745	2045

All flanged connections and cut outs as per AS. 2129 Table "E"
Tolerances of overall and connection dimensions $\pm 10\text{mm}$

SUPERCHILL AUSTRALIA PTY LTD
256 Princes HWY Dandenong 3175
Technical changes may occur without notification